



**CCTV Truer than life**

**Anti-grip Design, Tri-Axis Vandal Proof Dome Camera**

► **Product Numbers:**

- FN55VD420DN
- FN55VD480DN
- FN55VD525DN

► **Key Features:**

- Ultra Compact and light weight
- Anti-Grip with Tri-Axis Bracket
- IP66 with Waterproof Housing
- With 1/3" CCDs
- Stable picture quality
- Vandal proof design
- Day & Night
- Tamper proof screws

► **Technical Specifications:**

• Model	VD-420	VD-480	VD-525
• Effective Pixels 1/3" CCD Image Sensor	NTSC: 510 (H) x 492 (V)	NTSC: 771 (H) x 492 (V)	NTSC: 771 (H) x 492 (V)
• Horizontal resolution	420 TVL	480 TVL	540 TVL
• Minimum Illumination	0.1 Lux		
• S/N Ratio	more than 48dB		
• Shutter Speed	AES: 1/50(60) -1/100,000 sec.		
• Gamma Correction	0.45		
• Aperture Correction	Vertical & Horizontal		
• Lens	4.3mm (standard), 2.5mm, 3.6mm, 6mm, 8mm, 12mm (option)		
• BLC	Full Auto		
• Scanning System	2:1 Interlace		
• Synchronization	Internal		
• Gain Control	Auto		
• Storage Temperature	-30°C / +60°C		
• Operating Temperature	-20°C / +45°C		
• Power Source	DC12V±10%		
• Power Consumption	75mA		
• Dimensions	128mm x 128mm x 99.5mm		
• Weight	430g		



► **Tri-Axis Rotation:**

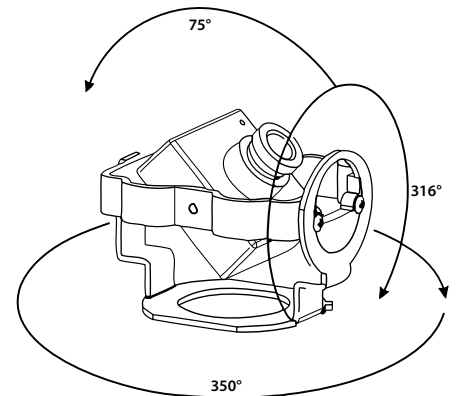

► **Physical Dimensions:**

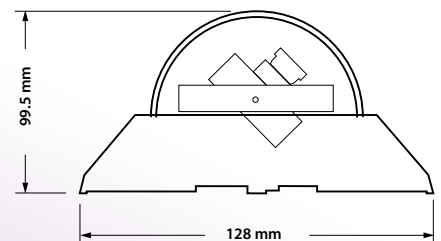

Design and specifications are subject to change without notice.