



CCTV Truer than life

**Anti-Grip Design,
Tri-Axis, Dome Camera**

► **Product Numbers:**

- FN55DC420DN
- FN55DC480DN

► **Key Features:**

- Ultra Compact and light weight
- Anti-Grip with Tri-Axis Bracket
- With 1/3" CCD
- Stable picture quality
- Day & Night
- ABS housing
- Tamper proof screws



► **Technical Specifications:**

Model	DC-420	DC-480
Image Sensor	1/3" CCD IMAGE SENSOR	
Horizontal resolution	420 TV Lines	480 TV Lines
Effective Pixels	NTSC: 510(H) x 492(V)	NTSC: 771(H) x 492(V)
Scanning System	2:1 interlace	
Synchronization	Internal	
S/N Ratio	More than 48dB	
Gamma Correction	0.45	
Shutter Speed	AES: 1/50 (60) – 1/100,000sec.	
Minimum Illumination	0.1 Lux	
Lens	Board Lens 4.3mm(Standard), 2.5mm, 3.6mm, 6mm, 8mm, 12mm(Optional)	
Auto Gain Control	Full Auto	
Backlight Compensation	Full Auto	
Power Requirement	Standard: DC12V±10%	
Dimensions L x M x H	128 mm x 128 mm x 99.5 mm	
Net Weight	200g	

► **Tri-Axis Rotation:**

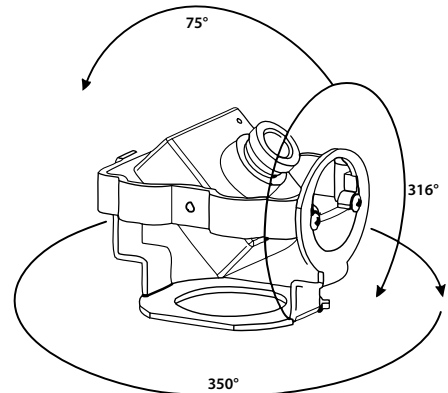

► **Physical Dimensions:**

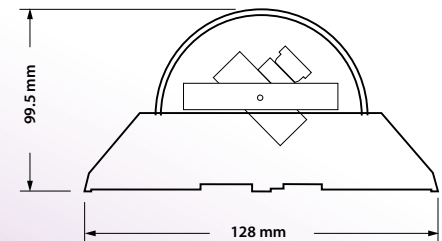

Design and specifications are subject to change without notice.